

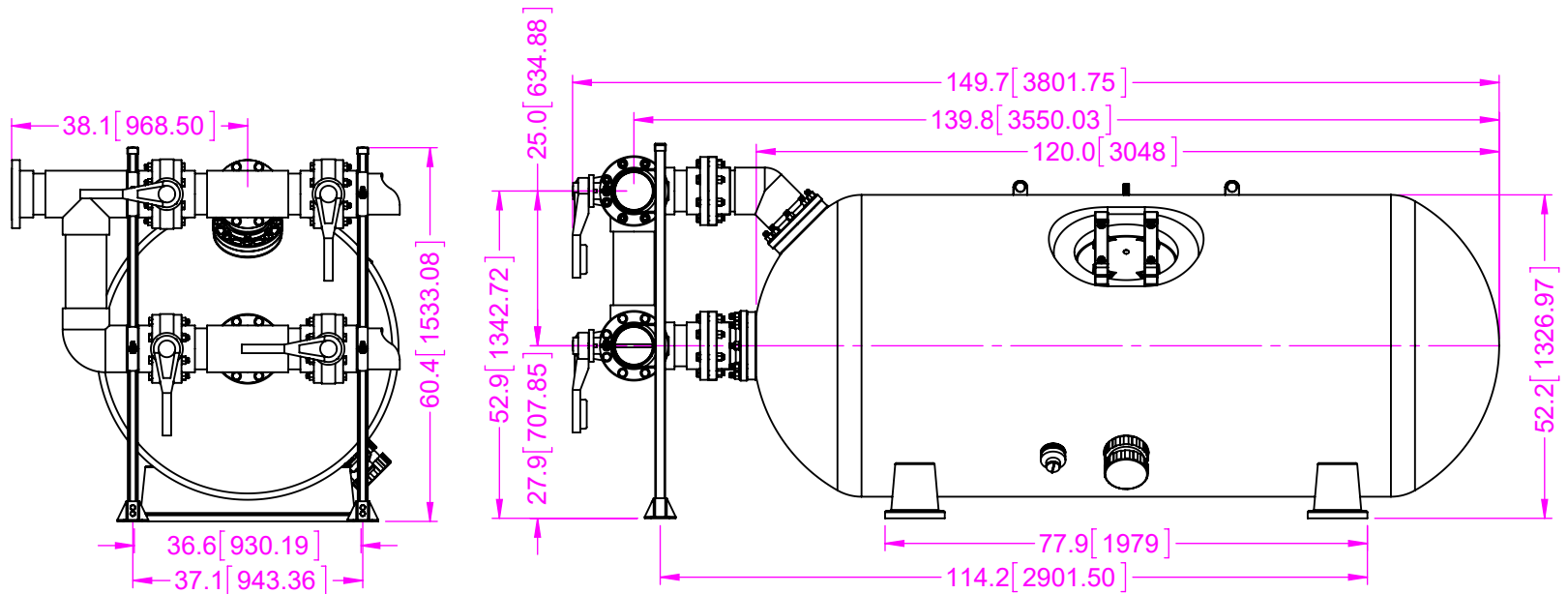

SEE SHEET #2  
FOR DETAILS

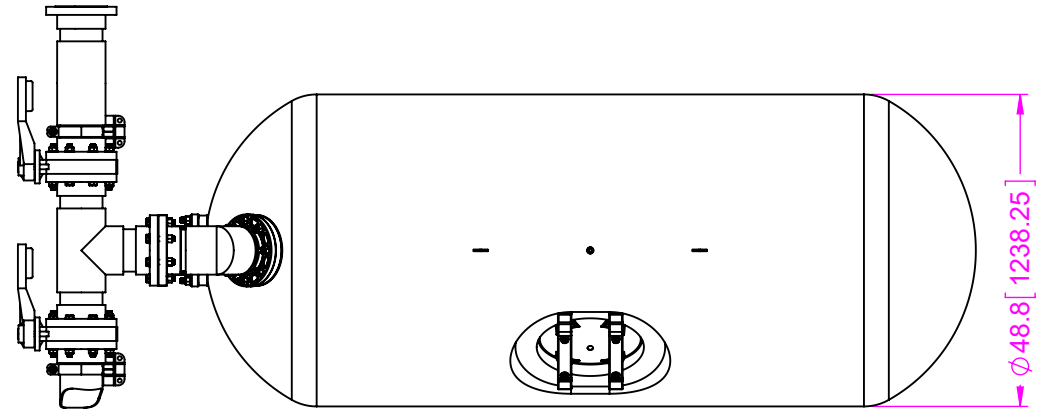

<b>FILTER DATA (FOR EACH FILTER)</b>		<b>GENERAL NOTES:</b>		DATE: ___/___/2020		DATE: ___/___/2020			
TOTAL SURFACE AREA:	37 SQ.FT.	1. MEDIA NOT INCLUDED WITH FILTER.		CUSTOMER:		ENG: JS			
MAX WORKING PRESSURE:	58 PSI	2. CONCRETE SLAB TO BE DESIGNED BY OTHERS.		DATE: ___/___/2020		DATE: ___/___/2020		<b>MICRON 48X120 HORIZONTAL FILTER RIGHT-WITH 6" FLANGE CONNECTIONS &amp; MANUAL 4-VALVE MANIFOLD</b>	
MAX FLOW RATE:	20 GPM/SQ.FT.	3. DRAWING MAY INCLUDE ITEMS SHOWN WHICH ARE NOT BEING SUPPLIED BY WATERCO. PLEASE REFER TO QUOTE FOR LIST OF ITEMS SUPPLIED.		PROD. MGR.: PG		DRN BY: RWS, Jr.			
<b>ESTIMATED MEDIA AMOUNTS</b>		4. FILTER MADE FROM HIGH STRENGTH FIBERGLASS AND RESINS.						SHEET: 1 OF 2	
SAND:	3,900 LBS.	5. ALL INTERNAL FILTER COMPONENTS CONSTRUCTED OF SCHEDULE 80 PVC.						REV: 1	
GRAVEL:	1,600 LBS.							SCALE: 1:30	
<b>WEIGHTS (APPROXIMATE)</b>								DATE: 4/20/2020	
FILTER SHIPPING WEIGHT:	1,350 LBS.							CUSTOMER:	
FILTER OPERATING WEIGHT:	12,900 LBS.								

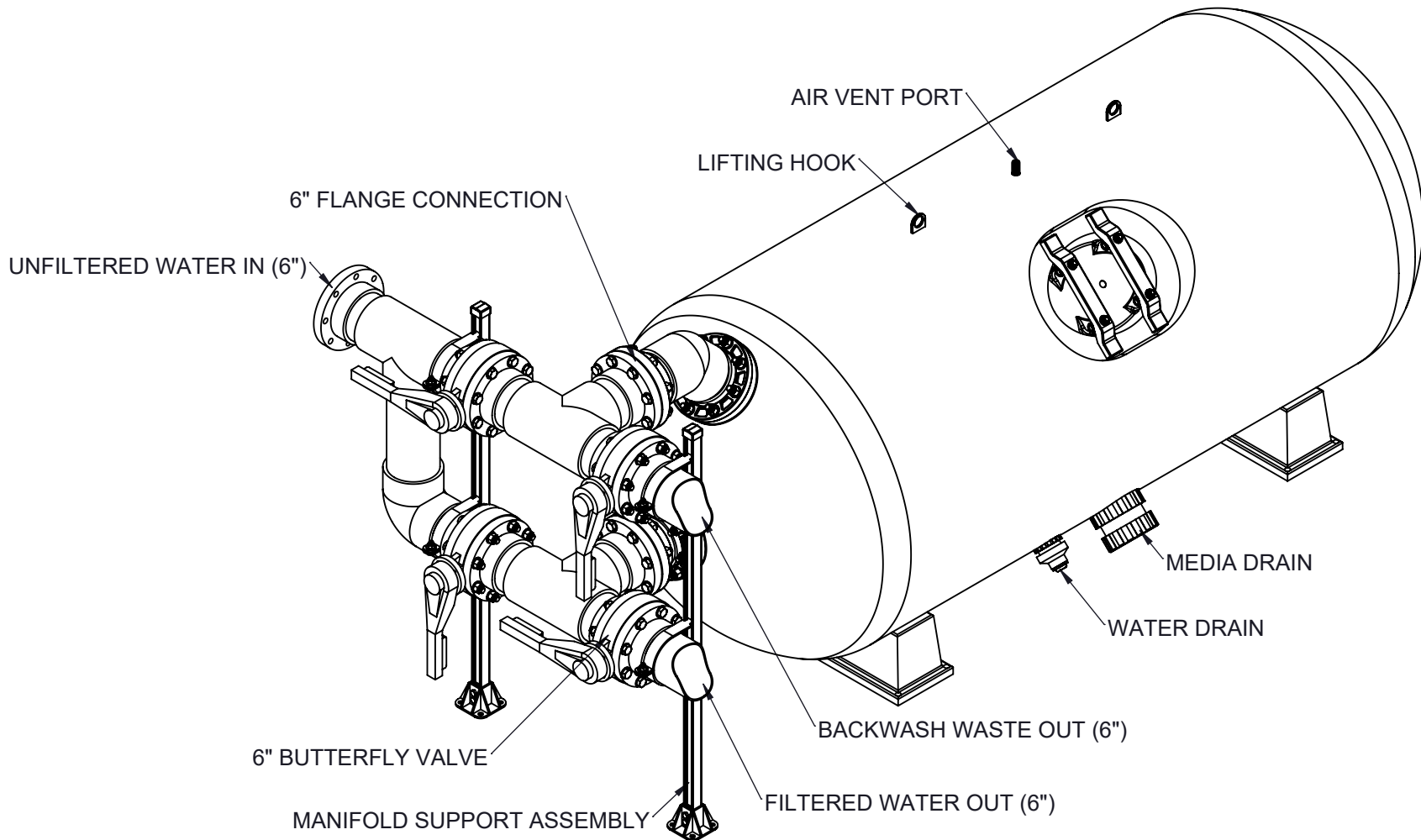

<b>FILTER DATA (FOR EACH FILTER)</b>	
TOTAL SURFACE AREA:	37 SQ.FT.
MAX WORKING PRESSURE:	58 PSI
MAX FLOW RATE:	20 GPM/SQ.FT
<b>ESTIMATED MEDIA AMOUNTS</b>	
SAND:	3,900 LBS.
GRAVEL:	1,600 LBS.
<b>WEIGHTS (APPROXIMATE)</b>	
FILTER SHIPPING WEIGHT:	1,350 LBS.
FILTER OPERATING WEIGHT:	12,900 LBS.

**GENERAL NOTES:**

1. MEDIA NOT INCLUDED WITH FILTER.
2. CONCRETE SLAB TO BE DESIGNED BY OTHERS.
3. DRAWING MAY INCLUDE ITEMS SHOWN WHICH ARE NOT BEING SUPPLIED BY WATERCO. PLEASE REFER TO QUOTE FOR LIST OF ITEMS SUPPLIED.
4. FILTER MADE FROM HIGH STRENGTH FIBERGLASS AND RESINS.
5. ALL INTERNAL FILTER COMPONENTS CONSTRUCTED OF SCHEDULE 80 PVC.

DATE: ___/___/2020	DATE: ___/___/2020
CUSTOMER:	ENG: JS
DATE: ___/___/2020	DATE: ___/___/2020
PROD. MGR.: PG	DRN BY: RWS, Jr.



**MICRON 48X120 HORIZONTAL FILTER  
RIGHT-WITH 6" FLANGE CONNECTIONS  
& MANUAL 4-VALVE MANIFOLD**

DRAWING TITLE: <b>48X120LR-M4VFH6X6-REV1</b>		SHEET: <b>2 OF 2</b>	REV: <b>1</b>
SCALE: <b>NTS</b>	DATE: <b>4/20/2020</b>	CUSTOMER:	